

SOLAR FLOOD LIGHT 300W

LD-**300W**



Application Place:

It is widely used in home lighting, streets and roads, residential areas, scenic spots, parks, squares, private gardens and other public places, also used for night lighting of advertising board, and construction outdoor lighting, easy to install, energy saving, no need to pay electric fee, longer life span.

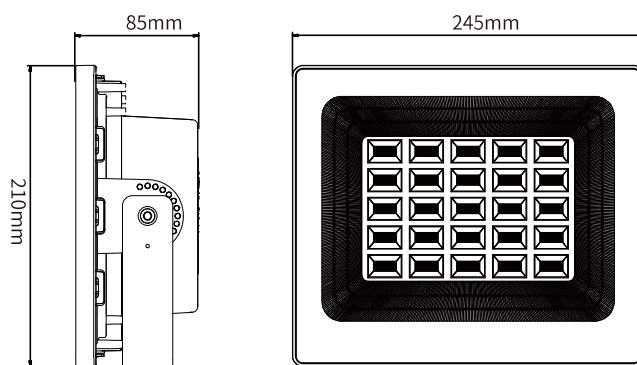

Product Parameters

Model	LD-300W
Solar Panel	5V 50W polysilicone, 25 years lifetime;
Battery	3.2V 45000mAh LiFePO4 Battery, 12 years life time
Light Source	180lm/W SMD USA Cree LED 3000K-6500K
Charging Time	4-6 hours
Lighting Time	All night lighting, with remote controller
Solar Panel Dimension	535*515*25mm
Cable Length	2.4 meters with golden connector
Lamp Viewing Angle	90°
Warranty	more than 10 years

Product Display

ON key: turn on

OFF key: turn off

AUTO key: Reset, 6+X overnight lighting mode

6H key: lights off after 6 hours

8H key: lights off after 8 hours

85% key: reduce 15% power

70% key: reduce 30% power

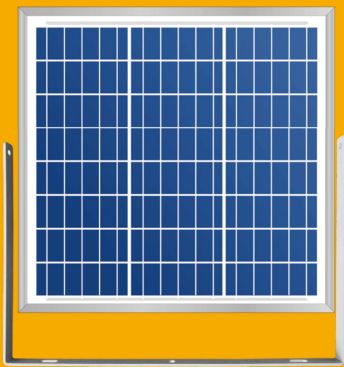
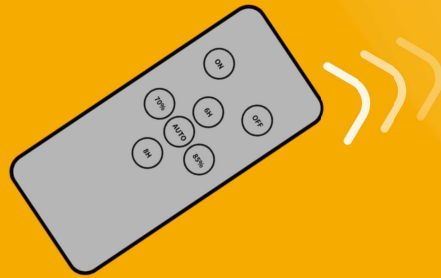

Solar Panel + Bracket



Lamp Holder



Remote Control



M6 Hex Key



M6x20 Hexagon socket bolt



M5 Hex Key



M6 Flat gasket



M6 Nut



Packaging Display

SOLAR FLOOD LIGHT

Product Advantage

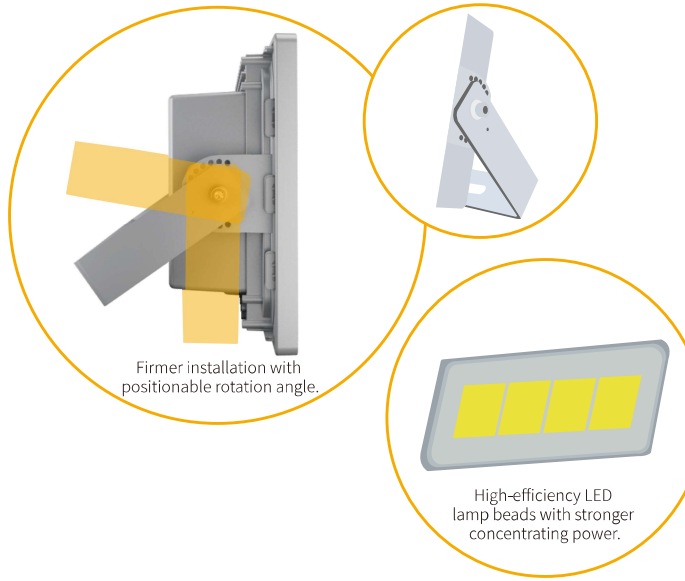

- Independent R&D, patented products, integrated design, modular production, one-click installation.
- Powered by Cree LED™ Products, with 100000 hrs life span.
- With LiFePO4 battery, high safety, long life span.
- Diamond surface reflection process, reflecting light source, enhancing the brightness of the lighting effectively.
- Widened and thickened bracket, positionable angle, installation stable & firm.
- With PC outdoor optical lens. High light transmittance, high temperature resistance and aging resistance.
- Gold-plated aviation plug, higher transmission speed, more safer.
- Low voltage design, safe and reliable.
- Integrated package, convenient transportation.

- 1 PC outdoor optical lens
- 2 Diamond surface reflection technology
- 3 Waterproof ring
- 4 High efficiency LED
- 5 Control & drive integrated lamp board
- 6 LiFePO4 battery
- 7 Built in military plug
- 8 High density aluminum magnesium alloy die casting
- 9 Bracket

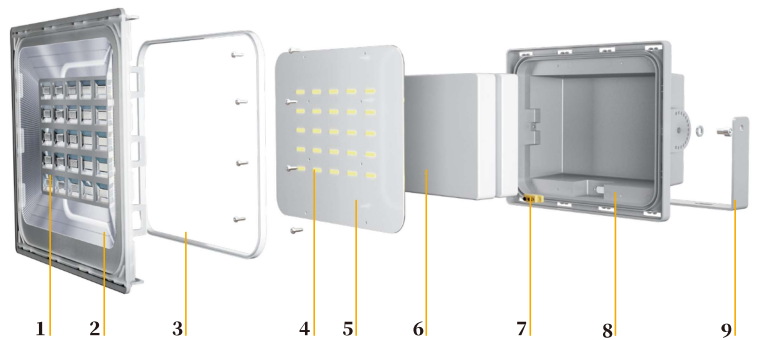

Installation Cases and Applicable Scenarios

